



Adkins Dealers

Updating to Main Board Version 1891 900 Pro

1. Differences Compared to Previous Version

1.1

There is better control of the Pre-Heat temperature. The temperature that this will heat to is what is set on the panel, even if lower than 70 degrees. E.g. if 40 degrees pre-heat is required, and this is set in that setting, this will be the temperature it heats to.

1.2

When using the system in Auto Mode, the speed is controlled by the programme, based on how long it senses film at the front film sensor. It takes around 3-5 meters (Approx. 20 minutes) once applied to the take up roller for it to have fully judged this speed and therefore for the speed to become consistent.

The speed in Link mode is based on the "Feed Speed" chosen in the settings. It is therefore important that this is set correctly based on the output speed of the printer so that there is no sudden change in speed once Link is activated.

2. Instructions for the upgrade to version 1891

2.1

Before proceeding, always ensure that a photo and record is taken of the settings being used (and the Filter Usage and Machine Runtime).

2.2

Before proceeding, always ensure that a photo and record is taken of the Advanced Parameters set.

Accessed via: Settings > ? > [Top Right Corner] > 18765

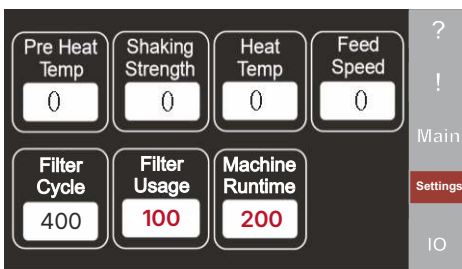

Para Monitor						
1	0	6	0	11	50	16 1
2	50	7	3000	12	2766	17 1
3	0	8	0	13	1024	18 1
4	0	9	0	14	2766	19 1
5	0	10	164	15	120	20 66



Adkins Dealers

Updating to Main Board Version 1891 900 Pro

To get to the password screen, Press setting button (Fig1), "?" Button (Fig2), Top right hand of the screen as shown below (Fig3). You will then see the password screen pop up (Fig4). Once the password **18765** has been entered you will see the Para Monitor screen.

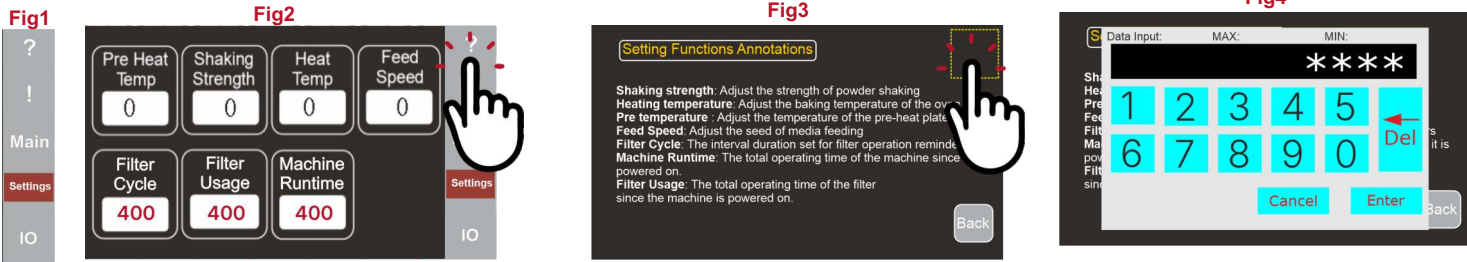

2.3

Power off the system, remove the side panel (touch screen side) and connect your PC to the systems' Main Board via a USB to USB-C cable. You should see a red LED illuminate on the Main Board at this point.



2.4

Open the Adkins firmware updater .exe file and select USB as the port / connection method option.

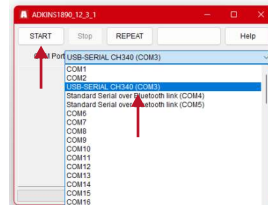

2.5

Click start and then power on the machine.



2.6

Once the update has finished, you will see that the system has fully loaded and the version shown in the top right corner will be the new version installed (1891). Power off the system.

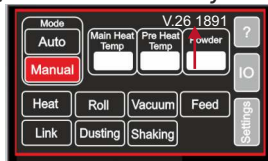

2.7

Disconnect your laptop and re-fit the side panel.

2.8

Navigate to the Advanced Parameters as shown above
(Accessed via: Settings > ? > [Top Right Corner] > 18765)



2.9

With the exception of 3 and 4, change the following Advanced Parameters to the below:

Para Monitor

1	1024	6	5000	11	1	16	1
2	50	7	16000*	12	1	17	1
3		8	0*	13	0	18	1
4		9	12000*	14	0	19	0
5	0	10	1	15	60	20	1160

Back

*Parameter 7, 8 and 9 will automatically set to 6000, 50 and 2000 respectively when setting these numbers, but please follow what is listed above.

2.10

Fully restart the system



2.11

Navigate back into the Advanced Parameters menu and set Parameters 13 and 14 respectively to the figures noted for the Filter Usage and Machine Runtime at step 2.1.

2.12

Restart the system.

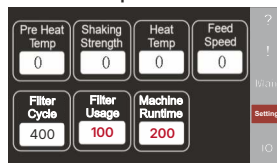

2.13

Go into the Calibrations menu (how to perform this is shown on the next page) and calibrate the Powder Weight sensor and calibrate the tension bar sensor.

2.14

Restart the system

2.15

Check and change the user settings back to how the customer had them set (Heat, Pre-Heat and Feed Speed).

2.16

Continue to use and maintain the system as advised by Adkins



Adkins Dealers

Updating to Main Board Version 1891 900 Pro

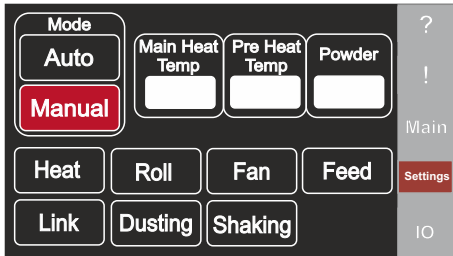

On the main screen Press "Settings".

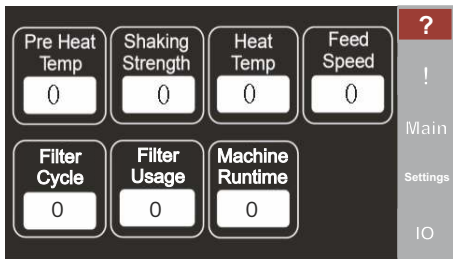

Once pressed you will be taken to this screen Press "?".

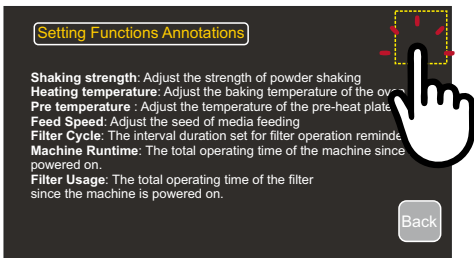

Next press into the top right hand corner to bring up the password screen

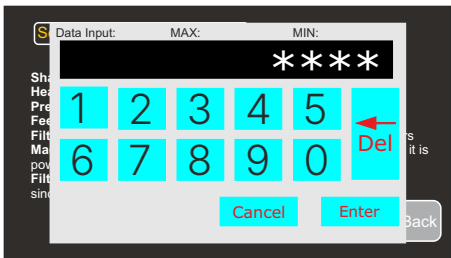

Enter Password **1234**, Then Enter button

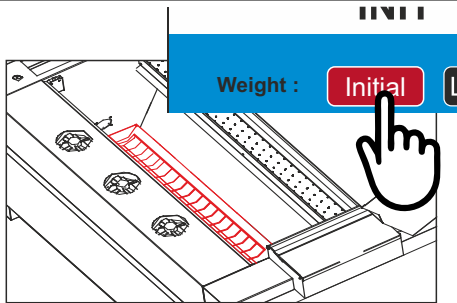
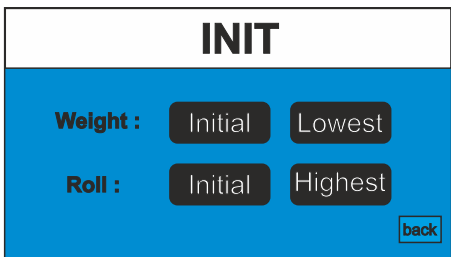

With no film or powder on the powder weight bar press the "Initial" button on the screen.

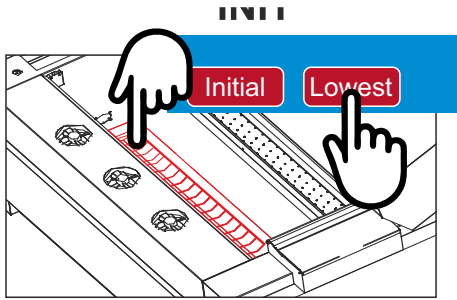

Push the bar down to the lowest point and then slowly lift up till you are around 50-75% from the lowest point. (70-90% if Auto Return Powder) Now press the "Lowest" button on the screen.

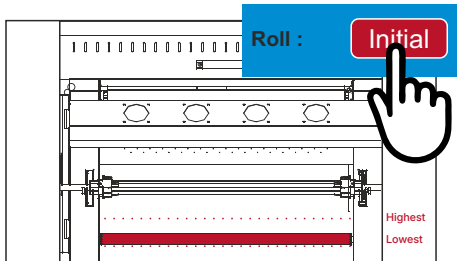

With no film on the Tension bar and at the lowest position press the "Initial" button on the screen.

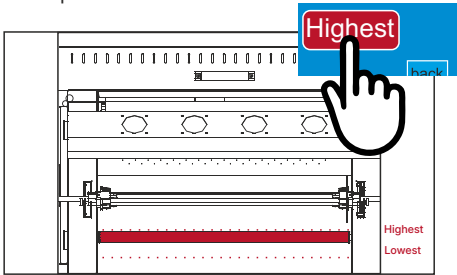

Lift the Tension bar to the highest position press the "Highest" button on the screen.

Press the "back" button to go back to the Main screen, then power off the machine wait 5 seconds and power the machine back on. The calibration has now been completed.

Calibration videos are available on YouTube @adkinsmachines